

# YAMAHA EQ-630 *RS*

*Natural Sound Stereo Graphic Equalizer*

*Independent Left and Right 10-Band  $\pm 12$  dB (2 dB Step) Graphic Equalizer*

*Spectrum Analyzer with Peak Hold Function*

*Independent Left and Right Channel Operation Display*

*4 User EQ Memories and 4 Preset EQ Memories*

*Remote Control Capability*

*Thank you for purchasing the YAMAHA EQ-630 stereo graphic equalizer.*

CENTER

## CONTENTS

SAFETY INSTRUCTIONS .....	1
CAUTION .....	2
CONNECTIONS .....	6
FRONT PANEL PARTS AND FUNCTIONS .....	7
NOTES ON REMOTE CONTROL TRANSMITTER .....	9
BEFORE OPERATION .....	10
OPERATIONS .....	11
SPECIFICATIONS .....	12
TROUBLESHOOTING .....	Back cover

## OWNER'S MANUAL



### IMPORTANT

Please record the serial number of your unit in the space below.

Model: **EQ-630**

Serial No.:

The serial number is located on the rear of the unit.

Retain this Owner's Manual in a safe place for future reference.

## SAFETY INSTRUCTIONS

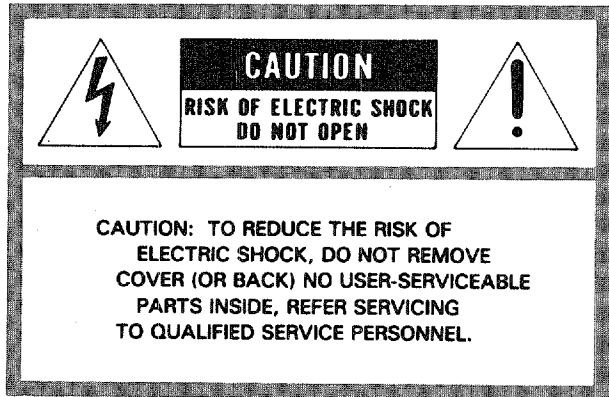

### • Explanation of Graphical Symbols

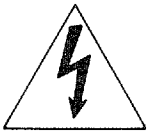

The lightning flash with arrowhead symbol, within an equilateral triangle, is intended to alert you to the presence of uninsulated "dangerous voltage" within the product's enclosure that may be of sufficient magnitude to constitute a risk of electric shock to persons.



The exclamation point within an equilateral triangle is intended to alert you to the presence of important operating and maintenance (servicing) instructions in the literature accompanying the appliance.

### WARNING

TO REDUCE THE RISK OF FIRE OR ELECTRIC SHOCK, DO NOT EXPOSE THIS APPLIANCE TO RAIN OR MOISTURE.

**1** Read Instructions — All the safety and operating instructions should be read before the appliance is operated.

**2** Retain Instructions — The safety and operating instructions should be retained for future reference.

**3** Heed Warnings — All warnings on the appliance and in the operating instructions should be adhered to.

**4** Follow Instructions — All operating and other instructions should be followed.

**5** Water and Moisture — The appliance should not be used near water — for example, near a bathtub, washbowl, kitchen sink, laundry tub, in a wet basement, or near a swimming pool, etc.

**6** Carts and Stands — The appliance should be used only with a cart or stand that is recommended by the manufacturer.

**6A** An appliance and cart combination should be moved with care. Quick stops, excessive force, and uneven surfaces may cause the appliance and cart combination to overturn.



**7** Wall or Ceiling Mounting — The appliance should be mounted to a wall or ceiling only as recommended by the manufacturer.

**8** Ventilation — The appliance should be situated so that its location or position does not interfere with its proper ventilation. For example, the appliance should not be situated on a bed, sofa, rug, or similar surface, that may block the ventilation openings; a cabinet that may impede the flow of air through the ventilation openings.

**9** Heat — The appliance should be situated away from heat sources such as radiators, stoves, or other appliances that produce heat.

**10** Power Sources — The appliance should be connected to a power supply only of the type described in the operating instructions or as marked on the appliance.

**11** Power-Cord Protection — Power-supply cords should be routed so that they are not likely to be walked on or pinched by items placed upon or against them, paying particular attention to cords and plugs, convenience receptacles, and the point where they exit from the appliance.

**12** Cleaning — The appliance should be cleaned only as recommended by the manufacturer.

**13** Nonuse Periods — The power cord of the appliance should be unplugged from the outlet when left unused for a long period of time.

**14** Object and Liquid Entry — Care should be taken so that objects do not fall into and liquids are not spilled into the inside of the appliance.

---

**CAUTION: READ THIS BEFORE OPERATING YOUR UNIT.**

---

**15** Damage Requiring Service — The appliance should be serviced by qualified service personnel when:

- A. The power-supply cord or the plug has been damaged; or
- B. Objects have fallen, or liquid has been spilled into the appliance; or
- C. The appliance has been exposed to rain; or
- D. The appliance does not appear to operate normally or exhibits a marked change in performance; or
- E. The appliance has been dropped, or the cabinet damaged.

**16** Servicing — The user should not attempt to service the appliance beyond those means described in the operating instructions. All other servicing should be referred to qualified service personnel.

**17** Grounding or Polarization — The precautions that should be taken so that the grounding or polarization of an appliance is not defeated.

**1.** The EQ-630 is a sophisticated graphic equalizer. To ensure proper operation for the best possible performance, please read this manual carefully.

**2.** Choose the installation location of your unit carefully. Avoid placing it in direct sunlight or close to a source of heat. Also avoid locations subject to vibration and excessive dust, heat, cold or moisture. Keep it away from such sources of hum as transformers or motors.

**3.** Do not install the unit on other component and do not place the television set or color monitor on the unit.

**4.** Do not open the cabinet as this might result in damage to the set, or electrical shock. If a foreign object should get into the set, contact your dealer.

**5.** To prevent lightning damage, pull out the power cord during an electrical storm.

**6.** When removing the power plug from the wall outlet, always pull directly on the plug; never pull the cord itself.

**7.** Do not use force when using the switches.

**8.** When moving the set be sure to first pull out the power plug and remove cords connected to other equipment.

**9.** Do not attempt to clean the unit with chemical solvent as this might damage the finish. Use a clean, dry cloth.

**10.** Be sure to read the "Troubleshooting" section for advice on common operating errors before concluding that your unit is faulty.

**11.** Keep this manual in a safe place for future reference.

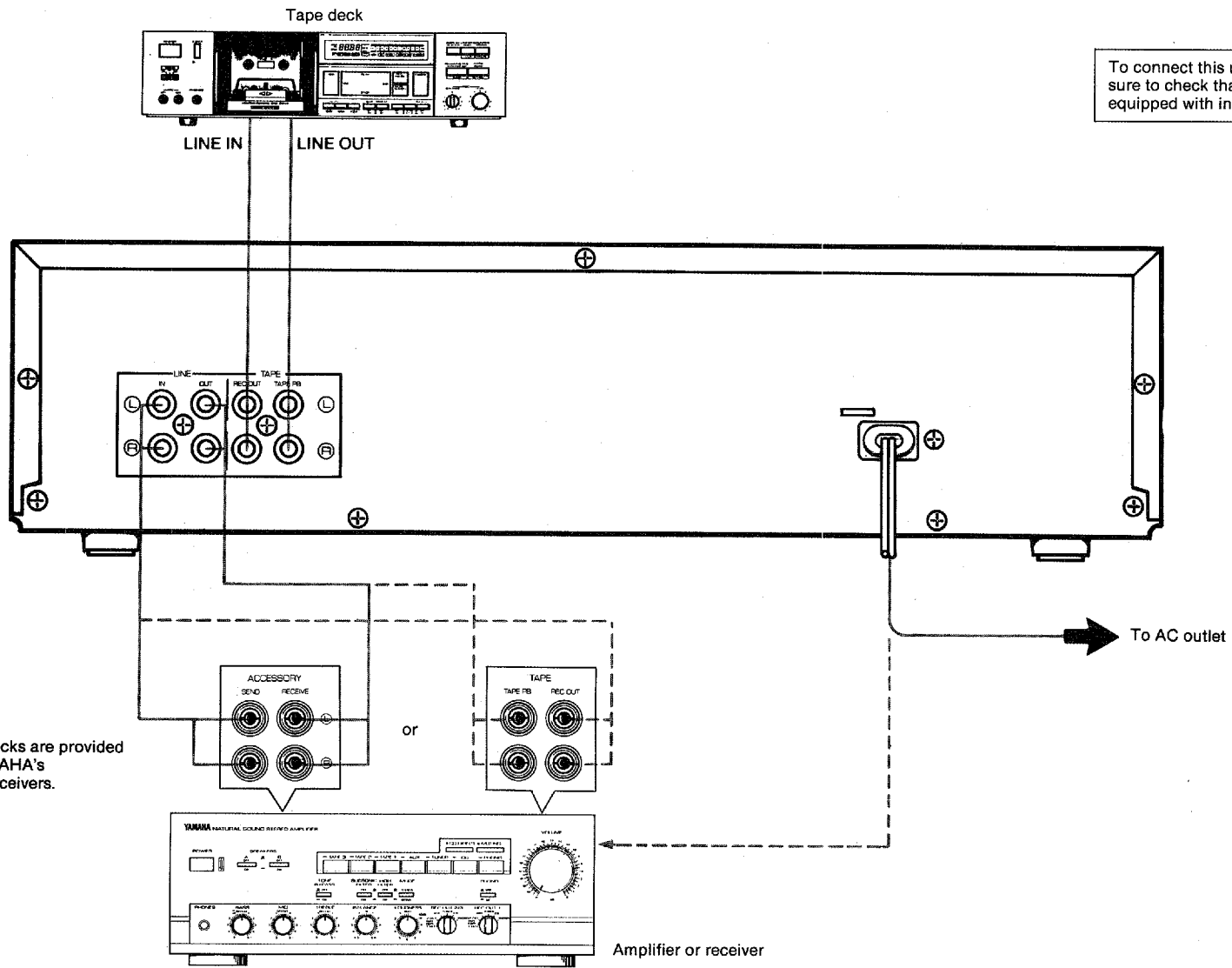

To connect this unit to a power amplifier, be sure to check that the power amplifier is equipped with input level controls.

The accessory jacks are provided on some of YAMAHA's amplifiers and receivers.

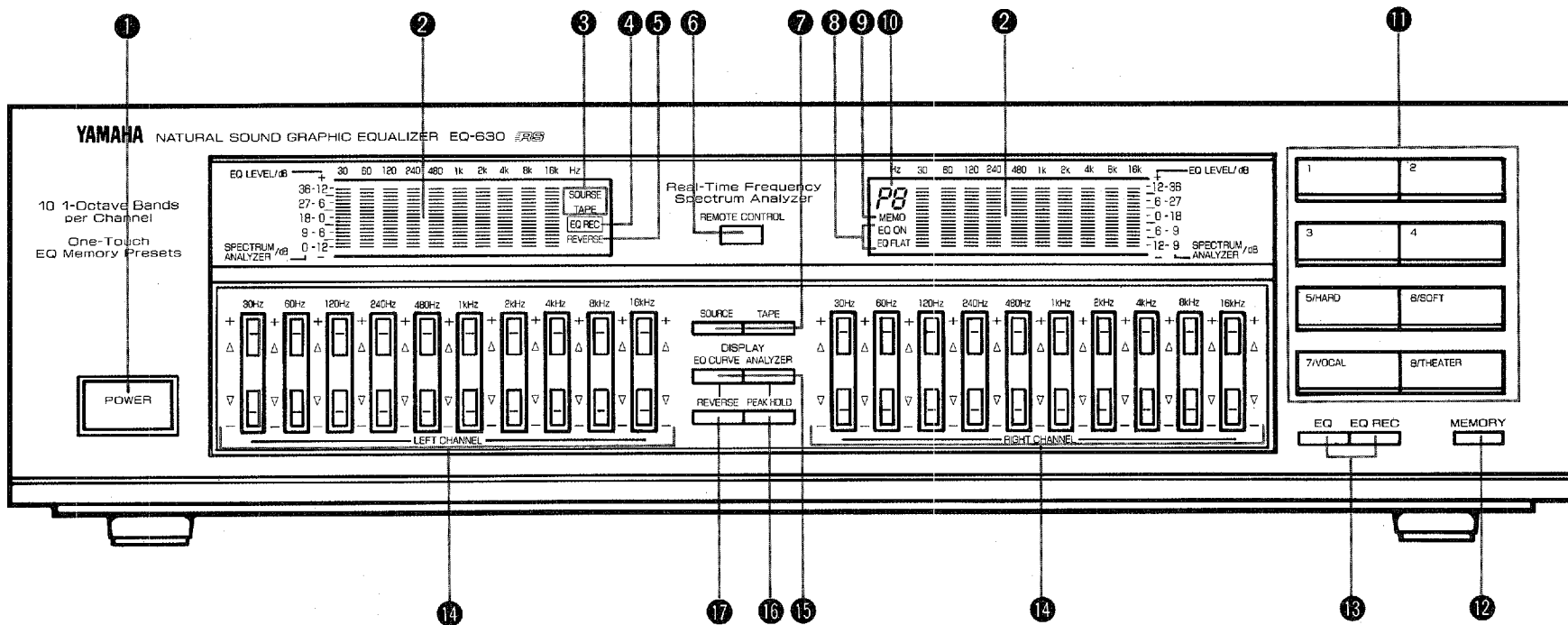

3

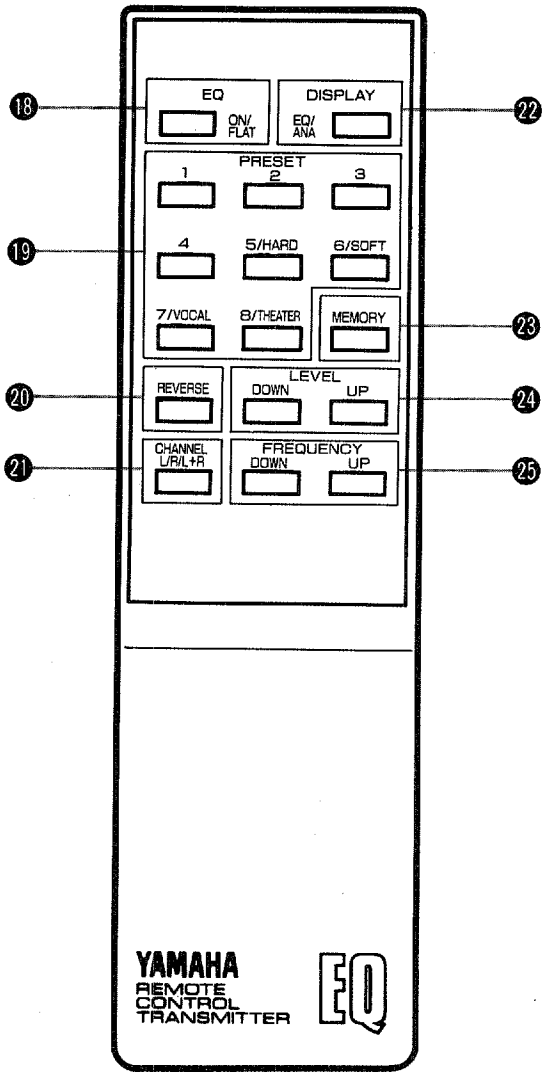

4

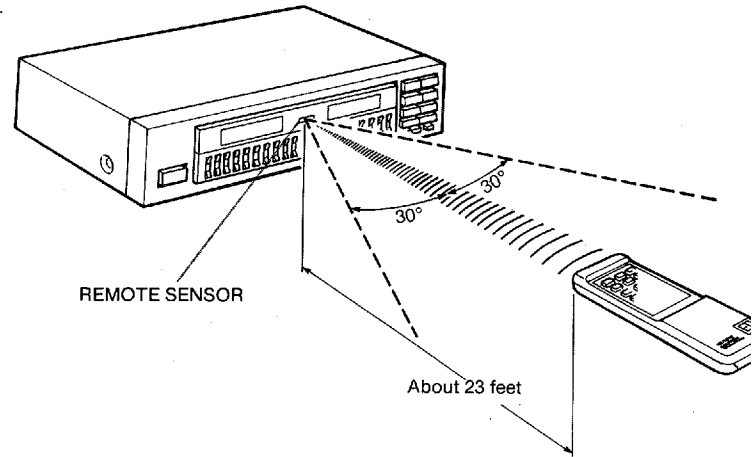

5

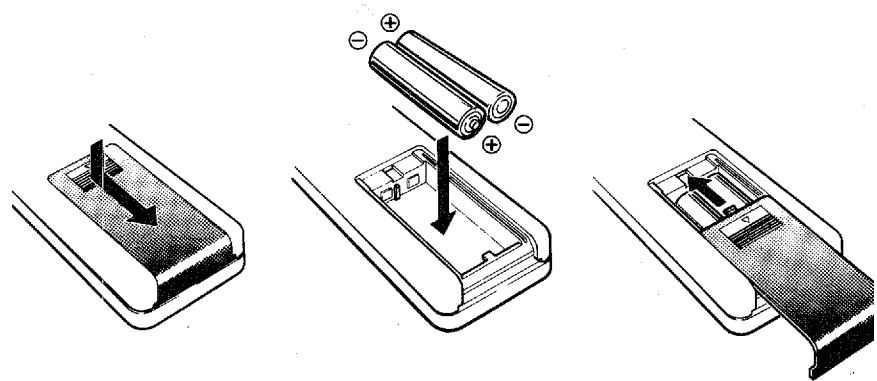

## CONNECTIONS

(See Fig. 11.)

- When connecting your equipment, turn the power to each unit off and make sure that you have correctly connected the Left (L) and Right (R) channels.
- For the amplifier or receiver connections, please refer to the amplifier or receiver owner's manual.

### ■ CONNECTING AN AMPLIFIER OR RECEIVER

Check from the connection diagram that you have made the correct connections. Please note that input procedures and program source selection may vary according to the capabilities of the amplifier or receiver and the connections between it and this unit.

#### • To connect an integrated amplifier or receiver using the **ACCESSORY jacks**

The **ACCESSORY** jacks are provided on some of Yamaha's amplifiers and receivers.

1. Connect the **SEND** jacks of the **ACCESSORY** jacks to the **LINE IN** of this unit.
2. Connect the **RECEIVE** jacks of the **ACCESSORY** jacks to the **LINE OUT** of this unit.

The program source selected with the integrated amplifier's or receiver's input selector can be equalized.

#### • To connect an integrated amplifier or receiver without using the **ACCESSORY jacks**

1. Connect the **REC OUT** jacks of the **TAPE** jacks to the **LINE IN** of this unit.
  2. Connect the **TAPE PB** jacks of the **TAPE** jacks to the **LINE OUT** of this unit.
- The following operations can be carried out via the amplifier or receiver:

Amp	Program Source	Setting
With a <b>REC OUT</b> selector.	Selected with the <b>REC OUT</b> Selector.	Set the <b>INPUT SELECTOR</b> to <b>TAPE</b> .
With a <b>TAPE MONITOR</b> switch.	Selected with the input selector.	Turn the <b>TAPE MONITOR</b> switch <b>ON</b> .

### ■ CONNECTING A TAPE DECK

Connect the tape deck to the **TAPE** jacks. Connect the **TAPE PB** jacks to the tape deck's **LINE OUT** terminal, and the **REC OUT** jacks to the tape deck's **LINE IN** jacks.

## FRONT PANEL PARTS AND FUNCTIONS

(See Fig. 2.)

### ① POWER switch

Press this switch to turn the unit ON. Press the switch again to turn the unit OFF.

#### NOTE

Even when the only equalizer is not in use, be sure that the power cord is connected and the POWER switch is set to ON.

Failure to do so may result in no sound or distorted sound.

### ② SPECTRUM ANALYZER/EQ LEVEL display

The spectra or equalizer levels are displayed.

The spectra are displayed using bars while the equalizer levels are displayed using dots.

### ③ Input indicators

The source selected by the input select buttons is indicated.

### ④ EQ REC indicator

Lights when the EQ REC button is pressed.

### ⑤ REVERSE indicator

Lights when the REVERSE button is pressed.

### ⑥ REMOTE CONTROL sensor

The signal from the provided remote control transmitter is received through this window.

### ⑦ Input select buttons

Press one of these buttons to select the source to be listened to.

**SOURCE:** To play the source connected to the amplifier, or to record onto cassette deck.

**TAPE:** To play cassette deck connected to the equalizer.

### ⑧ EQ ON/EQ FLAT indicator

Each time the EQ button is pressed, the EQ ON or EQ FLAT indicator lights alternately.

### ⑨ MEMO indicator

When the MEMORY button is pressed, this indicator flashes for about 5 seconds.

### ⑩ Preset No. indicator

The preset memory number (P1 to P8) is displayed.

### ⑪ Preset memory buttons

These buttons are used to store equalizer curves in the preset memory. By storing desired curves in the memory, they can be recalled by pressing these buttons.

Up to 4 equalizer curves can be stored in memory (1 ~ 4 buttons).

In addition, 4 memories are provided with storage of equalizer curves that are optimized for different types of music. These are stored under memory buttons 5 to 8, and cannot be rewritten by the user.

### ⑫ MEMORY button

To store the equalizer curve being displayed in memory, press this button.

Then, while the MEMO indicator is flashing (for about 5 seconds), press one of the preset memory buttons (1 — 4).

### ⑬ EQ button and EQ REC button

To start equalization of a sound, press the EQ button so that the EQ ON indicator lights.

To record the equalized sound, press the EQ button then, the EQ REC button so that the EQ REC indicator lights.

When equalization is not desired, press the EQ button so that the EQ FLAT indicator lights.

Each time the EQ button is pressed, equalized sound or sound without the equalization effect can be heard alternately.



#### 14 Equalizer level buttons

Independent level controls for the right, left or both channels are provided for each of the ten frequency bands with a +12 dB range of equalization. These button operations are effective only when the EQ button is set to ON even during the display changes.

##### ● 30 Hz band

Decreasing this level eliminates very low frequency rumble, or compensates a warped disc.

Increasing this level emphasizes the very low frequencies.

##### ● 60 Hz band

Decreasing this level reduces AC line hum and the lower tone.

Increasing this level emphasizes low tones, such as pipe organ, drums, bass, etc.

##### ● 120 Hz band

This range supports the lower end of the music and controls overall depth.

Decrease this level to eliminate "boomy bass" caused by room acoustics.

##### ● 240 Hz band

This is the middle-to-lower tone range, but it has an effect on the overall sound. Mainly, the richness of the strings can be controlled. When strings are overly warm under actual listening conditions, decrease this level.

##### ● 480 Hz band

This range is the foundation of music including both instruments and the human voice and it controls the overall power of the sound. As this level is increased, middle range sound will become more forward.

##### ● 1 kHz band

This range affects the presence of the music (depth of tone), and is especially effective when playing back vocals. Increasing or decreasing this level will cause the vocals to be more "up front" or more reserved.

##### ● 2 kHz band

This is the frequency range where the human ear is most sensitive. Boosting the level slightly will add brilliance, crispness, etc. to instruments. Cutting the level slightly makes for easy listening.

##### ● 4 kHz band

The human ear is also highly sensitive in this range. Mainly effective for increasing/decreasing the harmonics of the primary tone. Boosting this range a bit makes strings more intense. Over-intense, tiresome music is easily listened to when the level is decreased.

##### ● 8 kHz band

High frequency range. Strings, horns, etc. will be emphasized and this gives a slight difference in tone glaze and quality. Decreasing the level reduces over-emphasized consonants in vocals and objectionable tape hiss. Increasing the level, on the other hand, improves the sharpness of such instruments as cymbals.

##### ● 16 kHz band

Super-high frequency range. This affects high harmonics rather than the fundamental tones of the instruments themselves, and has an effect on the delicacy and atmosphere of the music. Boosting this level adds a delicate, fresh sound to cymbals, triangles, etc.

#### 15 DISPLAY mode buttons

These are used to select the display mode.

**EQ CURVE:** To display the equalizer levels.

**ANALYZER:** To display the spectrum.

#### 16 PEAK HOLD button

When the display is in spectrum analyzer mode, pressing this button holds the peak level for about 2 seconds.

Pressing this button again cancels this function, and the display shows the spectrum analyzer without peak holding.

#### 17 REVERSE button

Press this button to reverse the frequency characteristics of the equalizer curve. The REVERSE indicator lights, the emphasized frequency is de-emphasized and the de-emphasized frequency is emphasized.

This function is useful to listen to the original sound from a tape that was recorded for a car audio or radio cassette deck (tape recorded with emphasized high and low frequencies) on your home audio system.

1. Memorize the equalizer curve for a car audio or radio cassette deck.
2. Record the tape with the memorized equalizer curve.
3. To listen to the original sound of that tape, recall the memorized equalizer curve and press the REVERSE button, so that the REVERSE indicator lights.

In this way, a flat frequency response will be obtained and the original sound will be heard.

## NOTES ON REMOTE CONTROL TRANSMITTER

### ■ REMOTE CONTROL TRANSMITTER (See Fig. 3.)

#### 18 EQ ON/FLAT key

This key has the same function as the EQ button on the front panel.

#### 19 PRESET keys

These keys have the same function as the preset buttons on the front panel.

#### 20 REVERSE key

This key has the same function as the REVERSE button on the front panel.

#### 21 CHANNEL key

This key is used to select the channel to be operated on. Each time this key is pressed, the channel will be selected in the order: Left channel → Right channel → both Left and Right channels.

#### 22 DISPLAY key

This key has the same function as the DISPLAY mode buttons on the front panel. Each time this key is pressed, the equalizer levels or the spectrum analyzer will be displayed alternately.

#### 23 MEMORY key

This key has the same function as the MEMORY button on the front panel.

#### 24 LEVEL UP/DOWN keys

After selecting a frequency with the remote control transmitter's FREQUENCY UP/DOWN keys, adjust the level of the frequency with these keys.

#### 25 FREQUENCY UP/DOWN keys

These are used to select the frequency subject to equalizer level adjustment with the LEVEL UP/DOWN keys.

The dot of the level selected lights for about 7 seconds.

With the supplied remote control transmitter, most operations can remotely be carried out and the sound quality can be adjusted at your listening position.

### ■ REMOTE CONTROL OPERATION RANGE (See Fig. 4.)

The remote control transmitter can be used up to about 23 feet from your amplifier and must be aimed in its direction for proper operation. When the distance of the remote control range becomes short, replace the batteries.

### ■ BATTERY INSTALLATION (See Fig. 5.)

Install the supplied batteries as shown below.

1. Remove the battery compartment lid in the direction of the arrow.
2. Install the supplied batteries with the correct polarities.
3. Slide in the battery compartment lid until it clicks.

## BEFORE OPERATION

### Battery Cautions

If the battery is replaced incorrectly, dangerous leakage or corrosion may result. Be especially careful of the following points:

#### When replacing:

- Insert the battery with correct (+) and (-) indications correctly into the battery compartment.

#### Rechargeable batteries:

- There are two types of batteries; rechargeable and nonrechargeable. Check the cautions label on the battery before use.

#### To avoid accidents:

- Never disassemble, heat or throw a battery into a fire. When disposing, deal with batteries as inflammable matter.
- Do not short the (+) and (-) terminals directly.

#### When battery leakage occurs:

- Wipe off the liquid in the battery compartment and replace the battery with new one.

### ■ DISPLAY MODES

The display modes include the spectrum mode and equalizer level mode.

#### ● SPECTRUM DISPLAY

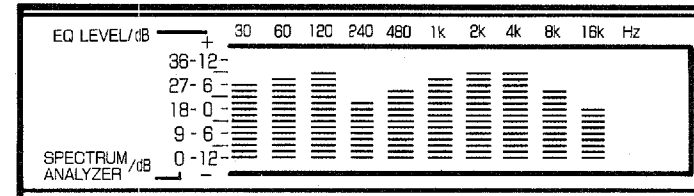

#### ● EQUALIZER LEVEL DISPLAY

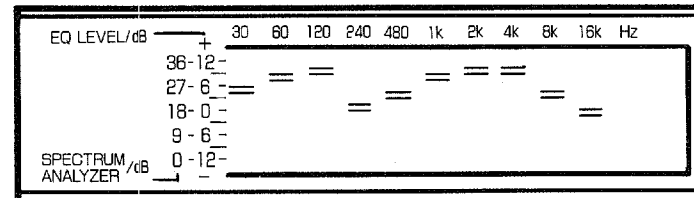

### ■ MEMORY FACILITY

The unit is provided with four user memories that can be rewritten by the user, with four fixed memories that cannot be modified by the user.

#### ● USER MEMORIES

Memories 1 to 4 can store four sets of left and right equalizer curves.

#### ● FIXED MEMORIES

Memories 5 to 8 stores the factory-set equalizer curves that were designed for optimum reproduction of different types of music. Each curve can be recalled by just pressing a button.

(New, user-set equalizer curves cannot be stored under these buttons.)

**5/HARD:** Pronounced setting, with enhanced low frequencies and sharp high frequencies, powerful bass and clear treble; suitable for rock and fusion music.

**6/SOFT:** Suitable for background music play. High frequencies which may be disturbing in some circumstances are attenuated for easy listening that is not tiring to the ears, even after long hours of play.

**7/VOCAL:** Setting providing crisp and clear vocals. Frequencies around 400 Hz, which correspond to men's voices and those around 1 kHz, corresponding to women's voices are boosted.

**8/THEATER:** Setting which makes the words of movie actors distinguishable. The frequencies most often used among various sounds in a movie belong to the 160 Hz and 400 Hz bands. These bands are boosted to make movie watching easier, with more distinguishable lines.

### ■ EQUALIZATION

1. Play the program source.

To listen to a program source from equipment connected to the amplifier, press the SOURCE button. The SOURCE indicator lights.

To listen to the tape deck connected to this unit, press the TAPE button. The TAPE indicator lights.

2. Set the EQ CURVE DISPLAY button to ON.

The equalizer levels will be displayed with dots.

If you want to adjust based on your hearing while observing the spectrum display, set the display mode for the analyzer mode with the ANALYZER button.

3. Set the EQ button to ON.

4. Press the equalizer level to obtain the desired equalizer curve.

When you want to control the equalizer with the remote control transmitter, first select the channel (Left channel, Right channel or both Left and Right channels) with the CHANNEL key, then select the frequency band with the FREQUENCY UP/DOWN keys, and finally adjust the level of the frequency with the LEVEL UP/DOWN keys.

- It is possible to change the factory-set equalizer curves (preset memory 5- as desired, but these original equalizer curves are always stored in memory

### ■ HOW TO STORE EQUALIZER CURVES IN MEMORY

1. Adjust the equalizer levels to obtain the equalizer curve to be stored.

2. Set the MEMORY button to ON.

The MEMO indicator will flash for about 5 seconds.

3. While the MEMO indicator is flashing, press one of memory buttons 1 to 4.

- \* When two or more level setups are stored under one preset memory button only the latest setup stored in memory will be stored.

### ■ HOW TO RECALL PRESET MEMORY

Press the preset memory button of the memory to be recalled.

The preset No. indicator lights to show the number of the button pressed, and the equalizer curve in the memory will be displayed.

If a memory is recalled while the EQ button is OFF, the stored equalizer curve will be displayed but the equalizer effect is not applied.

## SPECIFICATIONS

### LAST MEMORY FUNCTION

The button setting and curves levels immediately before turning the power off are stored.

When the POWER switch is pressed ON again, the setting and levels before power off will be recalled.

### BATTERY BACKUP

The equalizer curves stored in the preset memory buttons (1-4) are maintained by the lithium battery even while the power is OFF.

The battery should last for approximately five years, but it is recommended to replace the battery earlier. The battery must be replaced by a qualified YAMAHA service personnel.

Since the preset memories will be erased when replacing the battery, record the equalizer curves stored in the preset memory buttons beforehand, so you can quickly re-store your own equalizer curves again.

\* The factory preset memories cannot be erase or lost.

### WARNING: DO NOT ATTEMPT TO REPLACE THE LITHIUM BATTERY YOURSELF

If the lithium battery in the unit should need replacement, have the job done by qualified YAMAHA service personnel.

### RECORDING AN EQUALIZED PROGRAM SOURCE

The program source equalized with this unit can be recorded using the tape deck connected to the REC OUT jacks on the rear panel.

When this unit is connected to the ACCESSORY jacks of an amplifier, connect the tape deck as shown in figure 1

1. Press the SOURCE button.
2. Play the program source and adjust the equalizer levels.
3. Press the EQ REC button.
  - When recording without the equalization effect, press the EQ button so that the EQ FLAT indicator lights.
4. Adjust the recording level with the tape deck and start recording.

<b>Max. Output Voltage</b>	
(1 kHz, 0.1% T.H.D)	7V
<b>Rated Output Voltage</b>	1V
<b>Max. Input Voltage</b>	
(1 kHz)	7V
<b>Rated Input Voltage</b>	1V
<b>Input Impedance</b>	47 k-ohms
<b>Frequency Response</b>	10 Hz — 50 kHz, -1 dB
<b>Center Frequencies</b>	30 Hz, 60 Hz, 120 Hz, 240 Hz, 480 Hz, 1 kHz, 2 kHz, 4 kHz, 8 kHz, 16 kHz,
<b>Equalizer Control Range</b>	±12 dB
<b>Signal-to-Noise Ratio (IHF A Network)</b>	
At 1V output	105 dB/1V
<b>Total Harmonic Distortion</b>	
(20 Hz ~ 20 kHz, 1V output)	Less than 0.006%
<b>Power Requirements</b>	120V, 60 Hz
<b>Power Consumption</b>	10W
<b>Dimensions (W x H x D)</b>	435 x 122 x 271 mm (17-1/8" x 4-13/16" x 10-11/16")
<b>Weight</b>	3.5 kg (7 lbs. 11 oz.)
<b>Accessories</b>	Pin plug cords (2) Remote control transmitter (1) Dry battery size "AA" (R06) type (2) Power cord (1)

\* Specifications subject to change without notice.

## TROUBLESHOOTING

Before assuming that your unit is faulty, check by following troubleshooting list which details corrective action which you can take yourself. If the fault persists, or is mentioned in the list, turn off and disconnect the unit immediately, and get in touch with your nearest Yamaha dealer.

Fault	Cause	Cure
<b>Power is not supplied even through the power switch is turned on.</b>	<ul style="list-style-type: none"> <li>● The power plug is not securely plugged in.</li> </ul>	<ul style="list-style-type: none"> <li>● Plug it in securely.</li> </ul>
<b>No sound is heard.</b>	<ul style="list-style-type: none"> <li>● The input selector is not set correctly.</li> <li>● The pin plug is not properly connected.</li> </ul>	<ul style="list-style-type: none"> <li>● Press the correct input selector.</li> <li>● Check the connections.</li> </ul>
<b>There is no sound from one speaker.</b>	<ul style="list-style-type: none"> <li>● The pin plug is not properly connected.</li> </ul>	<ul style="list-style-type: none"> <li>● Check the connections.</li> </ul>
<b>Sound quality cannot be enhanced.</b>	<ul style="list-style-type: none"> <li>● The EQ button is not pressed.</li> </ul>	<ul style="list-style-type: none"> <li>● Press the EQ button.</li> </ul>
<b>Spectrum analyzer will not light up.</b>	<ul style="list-style-type: none"> <li>● The input selector is not set correctly.</li> <li>● The correct DISPLAY mode button is not pressed.</li> </ul>	<ul style="list-style-type: none"> <li>● Press the correct input selector.</li> <li>● Press the ANALYZER button.</li> </ul>
<b>Equalizer level will not light.</b>	<ul style="list-style-type: none"> <li>● The correct DISPLAY mode button is not pressed.</li> </ul>	<ul style="list-style-type: none"> <li>● Press the EQ CURVE button.</li> </ul>

# YAMAHA